

Do not open this packet until instructed to do so

2013 Virginia Science Olympiad



Circuit Lab

Division C

Team Number: _____

School Name: _____

Student Names: _____

Questions are each worth 1 point unless otherwise specified. All tiebreakers are listed in the test and count as part of the overall test score. Record all answers on the answer sheet

Directions: Fill in your response for each question in the space provided on the answer sheet corresponding to that question. Make sure you include units in your answers. Unless otherwise stated, assume all circuit components and devices are ideal.

Circuit 1 (Questions 1-6)

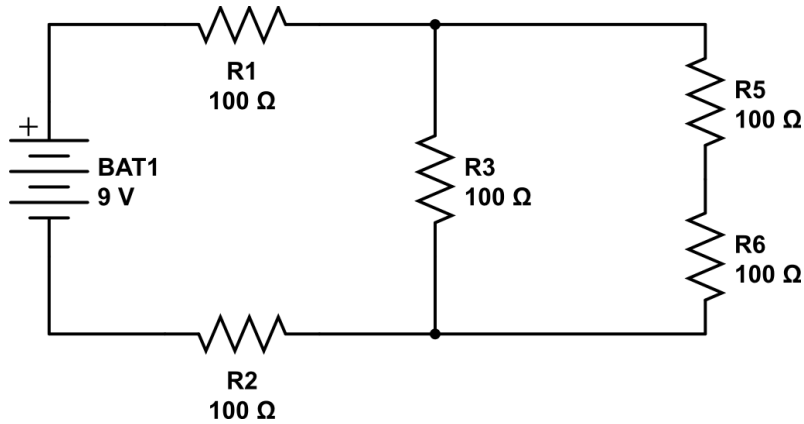

1. What is the equivalent resistance in circuit 1? (3 points)
2. Will the current through R3 be greater than, less than or equal to the current through R5?
3. Would the equivalent resistance of the circuit increase, decrease or stay the same if R3 was replaced with a wire?
4. What is the voltage across R3?
5. What is the current through R6 in terms of R3?
6. How much power is dissipated by R3? (2 points)

Circuit 2 (Questions 7-10)

Make sure you take note of the battery polarity.

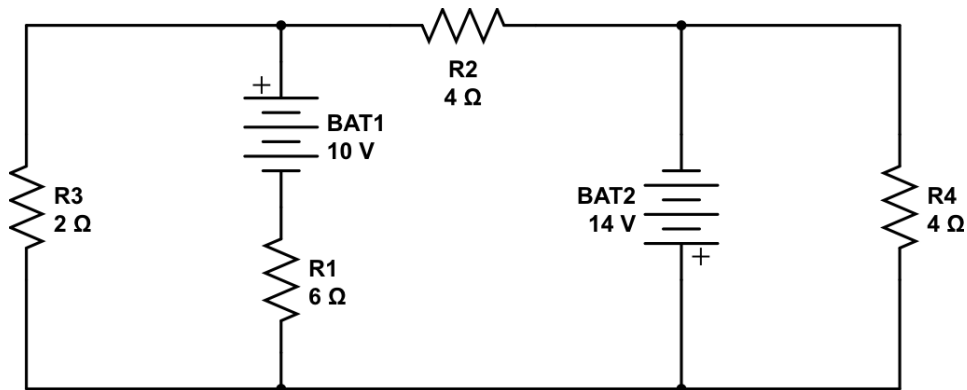

7. What is the current through R3? (2 points)

8. Write the current through R1 as an expression in terms of the currents through R3 and R2?
Choose whichever direction of current flow you prefer. (2 points)
9. What is the current through R2? (2 points)
10. What is the magnitude of the voltage across R4? (2 points)

Circuit 3 (Questions 11-15) – Tiebreaker #2

An RC circuit with an R of 1000Ω is in steady-state before a switch is thrown at time $t=0$. A voltage probe collects the voltage across the capacitor as a function of time for 0.001 seconds, starting with the moment the switch is thrown. The data is displayed below.

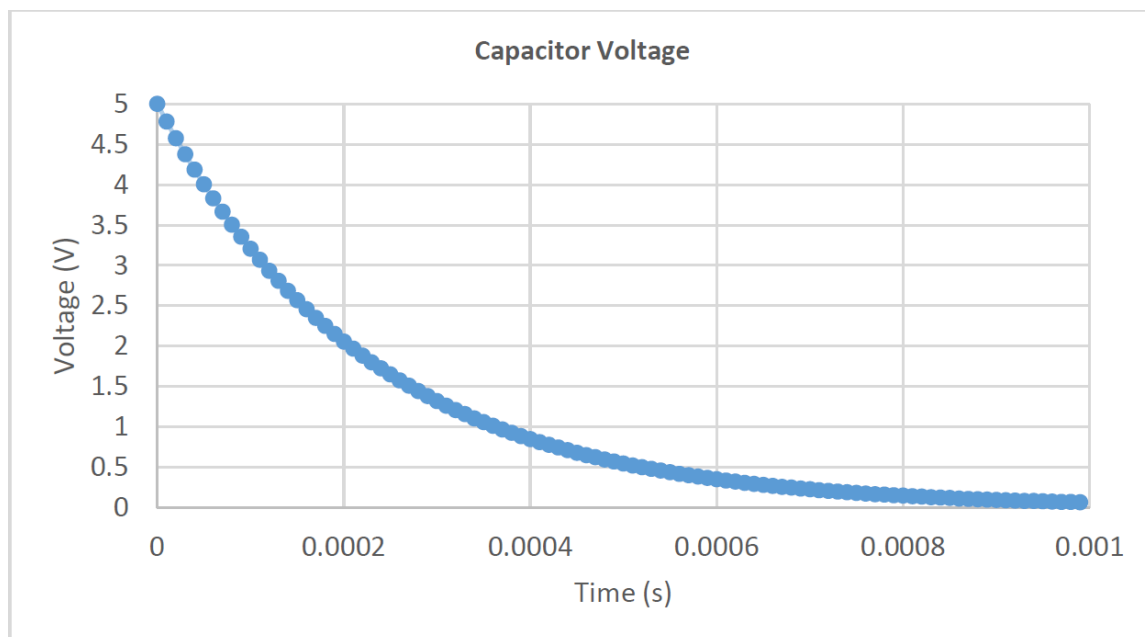

11. What is the current through the capacitor before the switch is thrown?
12. What is the time constant for this circuit? (2 points)
13. Using the information above, what is the capacitance of the capacitor? (2 points)
14. What is the current through the capacitor immediately after the switch is thrown? (2 points)
15. Draw a circuit that would produce this graph, assuming that the power source is removed from the circuit at time $t=0$. Label all components with their values. (5 points)

Circuit 4 (Questions 16-20)

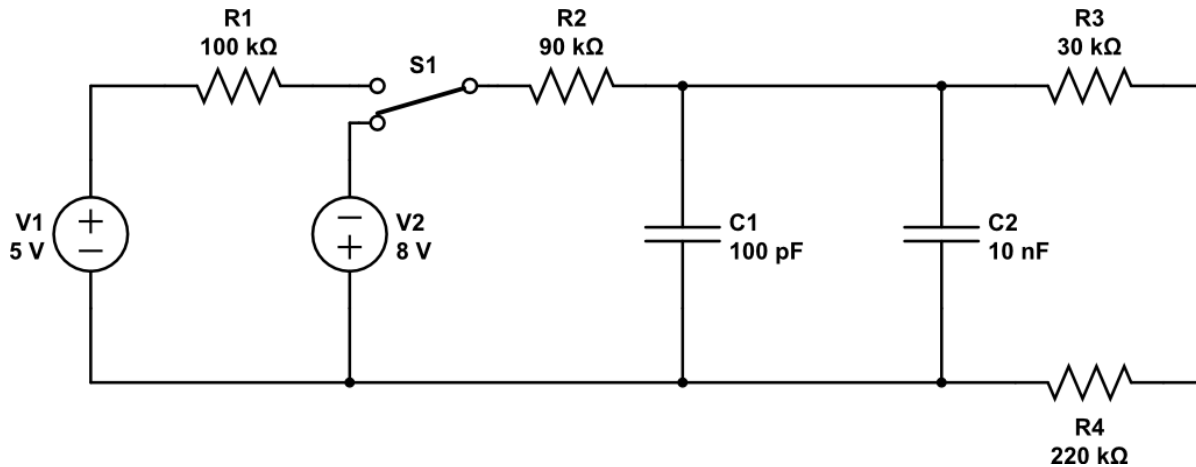

16. Switch S1 has been in the position shown above for a long time. What is the current through R2?
17. What is the capacitance of the combination of C1 and C2 (equivalent capacitance)?
18. Immediately after the switch moves to the top position, how much current runs through R1? (2 points)
19. Would the capacitor voltage change faster, slower or at the same rate when S1 is switched if the capacitance of C1 was higher?
20. Write the voltage across C2 as a function of time after the switch is thrown to the top position, using $t=0$ as the time when the switch is thrown. Show all calculations (5 points)

Circuit Analysis Laws (Questions 21-25)

Write the letter of the answer that goes with each circuit analysis concept (2 points each)

- | | |
|-----------------------------------|--|
| 21. Kirchhoff's Voltage Law (KVL) | a. Relates voltage, current and resistance |
| 22. Kirchhoff's Current Law (KCL) | b. The sum of voltages on a closed loop is 0 |
| 23. Ohm's Law | c. Reduction of a circuit to a voltage source and resistor |
| 24. Mesh Current Analysis | d. The sum of currents entering a node is 0 |
| 25. Thevenin Equivalent Circuit | e. Uses (b) for multiple loops simultaneously |

General Circuit Questions (Questions 26-34)

26. What is the name for the circuit element represented by the symbol to the right?
27. What is the internal resistance of an ideal voltmeter?
28. What is the internal resistance of an ideal ammeter?
29. What is the more common name of a Coulomb per second?
30. What is the more common name of a Joule per Coulomb?
31. What does the last colored bar on a resistor indicate about the resistor?
32. What is the purpose of a Wheatstone Bridge? (3 points)
33. Define resistivity. (2 points)
34. Define drift velocity. (2 points)



Lab Stations

Station 1 (Questions 35-40)

In front of you there is a circuit wired to a 9 V battery. Make as many current and/or voltage measurements as you need to answer the questions below, using the supplied multimeter or your own.

35. What is the resistance of the resistor labeled R1?

36. What is the resistance of the resistor labeled R2?

37. What is the resistance of the resistor labeled R3?

38. What is the equivalent resistance of the circuit? *(4 points)*

39. What is the resistance of the mystery resistor, R4? *(2 points)*

40. Draw a circuit diagram for this circuit, labeling the battery and resistors R1 – R4. *(6 points)*

Answer Sheet

1. _____

2. _____

3. _____

4. _____

5. _____

6. _____

7. _____

8. _____

9. _____

10. _____

11. _____

12. _____

13. _____

14. _____

15. Write answer below

16. _____

17. _____

18. _____

19. _____

20. _____

21. _____

22. _____

23. _____

24. _____

25. _____

26. _____

27. _____

28. _____

29. _____

30. _____

31. _____

19. Circuit diagram:

32. What is the purpose of a Wheatstone Bridge?

33. Define resistivity.

34. Define drift velocity.

Total: _____ / 97